



Mendip Stoves are created and constructed with thought and care. Design and quality are key in all our stoves. Each stove is tested for ease of use and durability, our designers have maintained each stove's own individual style to complement your fireplace or hearth. This combination of form and function make Mendip stoves a great choice. Each stove is named after a place in the beautiful Mendip hills in Somerset in which we are based.



Multi Fuel Versatility

Mendip stoves are built with the express ideals of being fully multi-fuel capable, this means that the combustion chamber and indeed all parts of the stove have been designed so that they can effectively burn wood and smokeless fuels. Mendip stoves have cast iron grates and heavy duty vermiculite linings to improve combustion, Mendip stoves now feature newly designed cast iron grates and each stove is carefully designed and tested. Attention to the manufacturing detail means that we are able to offer a 5 YEAR warranty against manufacturing defect on all Mendip stoves.

Burning Wood in a Smoke Control Area

Mendip stoves are tested for use as a wood burning stove in a smoke controlled area. Please check the symbol on each page to see if your specific choice is suitable for burning wood in a smoke control area.

Build Quality and Certification

Mendip Stoves are manufactured by an established company with a history of stove production, assuring you that your stove was beautifully built by experienced craftsman using today's most cutting edge technology. Mendip stoves are manufactured to exceed British standards with demand for quality at every stage from its heavy duty steel body to the ergonomically designed door handle, every detail has been meticulously considered.

The simple to operate air supplies have been carefully considered so as not only to ensure the most efficient combustion possible but also to pass a continuous stream of air over the front glass helping to keep your view of the fire unimpeded. All Mendip stoves are CE Marked. This means that your stove has been independently tested to exacting European standards for heating efficiency, safety and emissions.

PRODUCT INFORMATION

For an overview at a glance here are some symbols which give information about Mendip Stoves.



Extended operation

This is designed and tested under a continuous burn regime; this allows the stove to be burnt continuously. Single load burn refuel times are much longer for smokeless fuel than wood.



3 flow air system

The Mendip stoves range has a 3 flow air system to provide an optimal level of combustion air where it is needed for the combustion process. This results in an especially clean and efficient combustion.



Closed Combustion

This stove is capable of burning with external air via a connection pipe.



Construction

Model is manufactured from steel and fully welded construction.

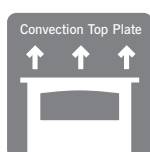
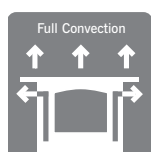

Convection stove

Mendip stoves are fitted with a convection top or full convection to give better heat distribution.

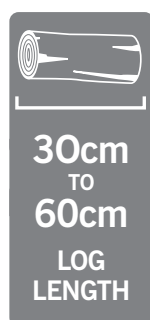

Log size

Mendip Stoves are designed for common lengths of logs 30cm to 60cm.



Air wash system

Model is fitted with an air wash system for cleaner glass.



Origin

Where it has been manufactured.



Suitable for burning wood in a Smoke control area

Mendip stoves carrying the tick logo are approved for burning wood in a smoke control area. Special note should be taken to the manufacturers instructions on burning the stove in a smoke control area.

DESIGN AND PRODUCT INNOVATION

Design and product innovation are essential ingredients in the development of a Mendip stove, our design of new parts is inspired by years of experience in the development of Wood and Coal stoves. We think through the product and look at ways to make it operate more effectively, for longer and burn more cleanly. This focus on our products is on-going as we strive to provide better products through design. From the first idea at drawing board stage to putting the finishing touches to the completed stove, we pride ourselves in the outstanding design of Mendip Stoves, with every stove being crafted with care. This accompanied with our aim to create a stove which can bring a touch of elegance to any room means we are constantly on the search for new technology to help us do this.

Our range has evolved over the years, but retained the timeless look which attracts many people to Mendip Stoves, and gained us the reputation of combining superior combustion techniques and efficiency with great aesthetics. Our stoves are as beautiful outside as the light they radiate from inside.

Award Winning Design

When designing a stove we consider many factors in the development process, much time, care and thought go into our designs to make them perform and look as good as is possible, so it is very gratifying to have been nominated for and won 'The best under 5kW multi-fuel stove of 2016' at the Hearth and Home Awards for our new stove 'The Woodland'. We are suitably proud.



Distinctive Products

In designing our stoves we are keen to give them a distinctive edge. We choose quality materials such as quality cast iron, steel and stainless steel to design individual stoves that have character and that work well.

Mendip stoves have developed the Ashcott stove which combines the use of steel and cast iron to produce an innovative stove.



Quality Components

All component parts are quality sourced from UK and European manufacturers. Now we have introduced cast iron doors on the Loxton range and the Mendip 5 and 8 stoves. These doors give the stoves a more rustic robust feel and with cleaner lines from the moulding process the stove has increased stability. The Loxton also now features the Mendip Stoves logo.

New bespoke fitted grates have been created from solid cast iron for Churchill, Loxton, Sqabox, Woodland and Somerton models.



Closed Combustion – Air Box

Mendip Stoves have developed a new air controller which through one simple single lever seamlessly controls primary, secondary and tertiary air for the appliance. This development is not only simpler to control, but is also cool to touch when the fire is operational.

Each stove has the potential to connect to external air, so your fire only draws the combustion air it needs from outside, this makes your stove more efficient and cleaner. (Loxton, Maxi, Churchill, Sqabox, Woodland & Somerton).



Mendip Stoves

ON TOUR



At the beach...

At Mendip Stoves
we are very lucky indeed...



Loxton, S

In celebration of this we name our stoves after
villages and towns in the Mendip Hills,



Camping on the farm...



please come
an



MENDIP STOVES THIS WAY

we live and work in one of
the most beautiful areas
of the UK.



Somerset



At the Bath and West Show



Cheddar Gorge...



We are here!

Join us on our little stove tour
and perhaps when you are next
in the west country pay us a visit.

MENDIP STOVES AND THE WOODLAND TRUST



The Woodland Trust plants, protects, and restores native woodlands. We look after more than 1,000 woods across the UK, all of which are free and open to the public.

The UK is one of the least wooded countries in Europe with just four per cent native tree cover. Only half of this is ancient woodland which is hundreds of years old and can never be replaced.

Our native woods are vital habitats for much loved species like the dormouse, red squirrel and song thrush. They are beautiful places for people of all ages to relax and play. Trees purify the air we breathe and provide shelter against the harsher elements. We need them, and they need our help.

Since we were formed 40 years ago, we have planted more than 23 million native trees. We have helped save more than 400 threatened ancient woods in the past ten years alone, and are undertaking a vast restoration project to bring 9,600 hectares of damaged ancient woodland back to life.

The Woodland Trust is delighted to welcome Mendip Stoves as a partner. Mendip Stoves support will help us achieve our vision of a richly wooded UK landscape and a public that respects woodland and shares our love of trees.

Mendip Stoves will help protect our precious and fragile woodlands by promoting the use of sustainable woodland fuel helping us plant more trees - and create lasting woodland for the benefit and enjoyment of generations.



Help the Woodland Trust to plant more trees

Thousands of people and organisations have planted woods with the Trust's help over the last 40 years, could you too?



Create your own wood with MOREwoods

MOREwoods is a UK-wide scheme providing practical and some financial support for the creation of woodland. Since starting the scheme in 2008, we've helped thousands of people and communities plant over 1,100 hectares of woodland.

If you would like to see how trees can enhance your land – whether to help wildlife flourish, create a secure and cheap supply of future firewood for your Mendip stove, or simply because of your love for trees, visit our website www.woodlandtrust.org.uk to find out more.



How Mendip Stoves helps

For every Mendip stove bought Mendip Stoves contribute £10 to the Woodland Trust. Our contributions will help to plant new native trees and protect Britain's ancient woodlands.

www.woodlandtrust.org.uk



SEE IT
BURNING



THE WOODLAND

The Woodland stove is the official wood stove for The Woodland Trust, Designed for Burning wood efficiently and cleanly.

Easy to use The Woodland stove has a multipurpose, three way air control adjustment system, allowing for optimum combustion. The tertiary air also aids post combustion of the flue gases; so ultimately, your stove will burn cleanly, creating as much energy from your fuel as possible.

The woodland stove has a good size fire box for standard cut logs, the latest technology in combustion for wood, a pre heated air wash system that will keep the glass clean, for your visual

pleasure. It also has a lovely wide viewing glass to make the fire come alive in your home, this stove has great presence!

Built with a high quality steel body and cast door the woodland stove has a nominal output of 4.5kw which will serve most internal spaces well. The radiating heat along with low distance to combustibles will help the stove fit nicely into your space with the best results.

We are positive this stove will warm your heart too; knowing you've contributed to renewal of our trees and woodlands brings the happiest of situations to purchasing this beautiful stove.

Features

- Cast iron door
- Milled stainless steel handle
- Cast iron grate
- Closed combustion
- Single air control

Dimensions

H x W x D

615 x 570 x 340
775 x 570 x 340

kW Output

wood coal

4.5kW 4.2kW

Efficiency

wood coal

79% 80%

Class Key



Models



Woodland



Woodland with Logstore



'Best Stove 2016'
Under 5 kW category
Hearth & Home Awards 2016





ASHCOTT

Nothing gives a welcome like the warm glow of a wood burning stove. The Ashcott is the latest design from Mendip, it has a deeply formed cast iron door, slim convection top plate and sculptured cast iron legs. The door has a magnetic mechanism for easier closing. The stoves compact design is a perfect blend of classic and contemporary styling. The fire is captured through the large ceramic glass window and the stove is finished with milled stainless steel handle and air control knob.

The Ashcott provides 4.7kW of efficient heat with a direct external air connection as standard.

Ashcott is also Eco-design Ready. Eco-design is a European-wide programme to lower emissions, which comes into force in the UK in 2022. Setting the standard for environmentally friendly stoves.

Features

- Cast iron door
- Milled stainless steel handle
- Closed combustion
- Single air control
- Magnetic door sealing

Dimensions

H x W x D

575 x 424 x 370

kW Output

wood coal

4.7kW -

Efficiency

wood coal

80.3% -

Class Key



Models



Ashcott





CHRISTON 550 & 750 FREESTANDING

The Christon 550 and 750 are a modern modular stove design; each stove features a large glossy glass front which emphasises the wood fire within. The Christon stove range is a full convector and it is ideal for a modern environment. Christon 550 and 750 have their own specifically designed logstore and side bench options. The glass door has a multipoint locking point

mechanism for secure closing. The Christons' combine cutting edge combustion technology with advanced firebox designed to burn wood so cleanly that emissions are lowered to minimal levels ensuring compliance with future Ecodesign emission standards.

Features

Glass fronted door
Multi-point door locking
Closed Combustion
Singular air control
Full convector model

Dimensions

H x W x D

550 x 550 x 360
550 x 750 x 360

kW Output

wood coal

4.8kW -
8.7kW

Efficiency

wood coal

78.4% -
77.8%

Class Key

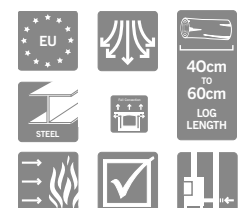

Models



Christon 550



Christon 750

CHRISTON 750



CHRISTON 550 LOGSTORE AND BENCH





CHRISTON 550 LOGSTORE



CHRISTON 750 LOGSTORE AND BENCH





LOXTON 3

The Loxton 3 is the smallest variant of the Loxton stove range. This small multi-fuel stove is designed especially for smaller rooms and fireplaces able to heat up to 40 cubic metres efficiently. The compact size allows the stove to fit snugly into the smallest of fireplaces, not overheating your room whilst delivering 3.0KW of heat for only 700g of wood per hour!

The 5mm steel constructed appliance is fitted with a cast iron grate, fully insulated vermiculite chamber and large ash pan. The Loxton 3 may be small but it has range leading efficiency figures providing high levels of heat for small quantities of wood or registered smokeless fuels. The Loxton 3 is now available with an optional small stove stand to raise the stove so making loading easier and give a more contemporary look.

Features

Cast iron door
Compact size
Cast iron grate
Milled stainless steel handle

Dimensions

H x W x D

Loxton 3
525 x 380 x 320

Stand
250 x 700 x 400

kW Output

wood coal

3.2kW 3.2kW

Efficiency

wood coal

86% 83%

Class Key

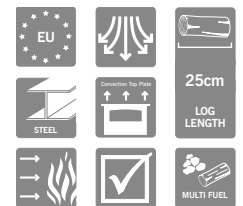

Models



Loxton 3



Loxton 3 on stand





LOXTON

The clean lines of the Loxton cast iron door and large glass window open the fire box to the room. The easy to operate single air control make adjustment simple and the latest three-flow clean burn air system allows for a more complete combustion. The Loxton is available in a large range of outputs from 3.2 to 10kW, so you can easily match the output to your room. The Loxton has been built with efficiency in mind, its construction incorporates many of the latest combustion

techniques to ensure that your stove burns wood and registered smokeless fuels efficiently and cleanly. Its pre-heated secondary air wash not only washes over the glass to help keep it clean and free of deposits but also feeds air directly into the heart of the fire. Its tertiary air aids post combustion of flue gases so your stove burns cleanly and uses as much energy from your fuel as possible.

Features

Cast iron door
 Cast iron grates
 Cast iron handle
 Closed combustion
 Single air control

Dimensions

H x W x D

606 x 510 x 320
 606 x 510 x 360
 660 x 510 x 410
 660 x 710 x 410

kW Output

wood coal

4.5kW 4.2kW
 6.0kW 6.0kW
 8.0kW 8.0kW
 10 kW 10 kW

Efficiency

wood coal

79% 80%
 83.6% 84.8%
 82.3% 80.8%
 78.7% 78.3%

Class Key

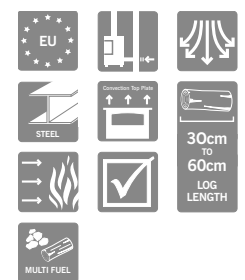

Models



Loxton 4.5



Loxton 6



Loxton 8



Loxton 10





LOXTON IVORY

The Loxton cast iron door is coated in a beautiful ivory enamel finish, each door has three coats of enamel to build up a mirror like deep glossy shine, the door is finished with Milled stainless steel handle which closes with a re-assuring firmness, through the large ceramic glass is an efficient fire box designed to burn wood and smokeless coal. The easy to operate single air control makes adjustment simple and the latest three-flow

clean burn air system allows for a more complete combustion. The Loxton is built with quality components, with a 5mm steel body, cast iron grates, door and an insulated chamber. We have built a stove with a pedigree, its construction incorporates many of the latest combustion techniques to ensure that your Loxton stove burns wood and registered smokeless fuels efficiently and cleanly.

Features

- Cast iron door
- Cast iron grates
- Milled Stainless handle
- Closed combustion
- Single air control

Dimensions

H x W x D

606 x 510 x 320

kW Output

wood coal

4.5kW 4.2kW

Efficiency

wood coal

79% 80%

Class Key



Models



Loxton Ivory 4.5





LOXTON LOGSTORES

The Loxton logstore model is fitted with a new cast iron door and handle, the logstore adds height and physical presence to the stove and makes it ideal for a freestanding position. The logstore version mirrors the freestanding Loxton model ranges in terms of contemporary design, styling and build quality, but also offers ideal log storage. The Loxton has been built with efficiency in mind; its construction incorporates many of the latest techniques to ensure that your stove burns wood and

smokeless fuels efficiently and cleanly. Its pre-heated secondary air wash not only washes over the glass to help keep it clean and free of deposits but also feeds air directly into the heart of the fire. With these features, the Loxton logstore is a stunning stove ideal as a feature in itself or placed simply in a position where the clear view of the fire is needed. Available in 4.5kW, 6.0kW, 8.0kW, 10kW models.

Features

Cast iron door
 Cast iron grates
 Cast iron handle
 Closed combustion
 Single air control
 Open log store

Dimensions

H x W x D

765 x 575 x 320
 960 x 510 x 360
 1040 x 510 x 410
 1040 x 710 x 410

kW Output

wood coal

4.5kW 4.2kW
 6.0kW 6.0kW
 8.0kW 8.0kW
 10 kW 10 kW

Efficiency

wood coal

79.0% 80.0%
 83.6% 84.8%
 82.3% 80.8%
 78.7% 78.3%

Class Key

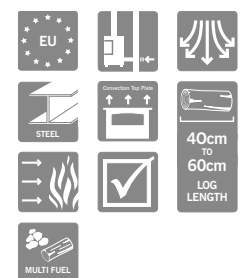

Models



Loxton 5 Maxi Convector



Loxton 6 Logstore



Loxton 8 Logstore



Loxton 10 Logstore





CHURCHILL

The Churchill exudes contemporary style, the stove has a softly curving glass door and easy open chromium handle which adds sophistication to the Churchill stove. The Churchill radiant model range is available in a choice of outputs, from 4.5 to 10 kW, so you can be sure that you will be getting the correctly sized stove that looks stylish and has the latest technology incorporated for your room.

Control of your stove is easy with the unique Universal air controlling system from Mendip, combustion air is adjusted with a single cool touch lever which precisely directs combustion air and enables better efficiency and more complete combustion of the wood fuel.

Churchill models are designed with an external air connection which allows combustion air to come from outside and not from the room. Another example of clever thinking from Mendip.

Features

- Curved door
- Cast iron grates
- Air cooled handle
- Closed combustion
- Single air control

Dimensions

H x W x D

- 606 x 510 x 380
- 606 x 510 x 420
- 660 x 510 x 460
- 660 x 710 x 480

kW Output

wood coal

- 4.5kW 4.2kW
- 6.0kW 6.0kW
- 8.0kW 8.0kW
- 10 kW 10 kW

Efficiency

wood coal

- 79.0% 80.0%
- 83.6% 84.8%
- 82.3% 80.8%
- 78.7% 78.3%

Class Key

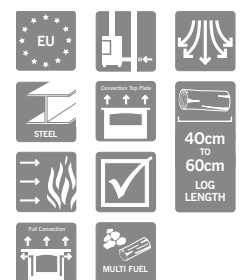

Models



Churchill 4.5



Churchill 6



Churchill 8



Churchill 10





CHURCHILL CONVECTION

Churchill convection stoves gently curved side panels and top plate give the Churchill a distinctively different look. A convection stove gives a better distribution of heat and can, therefore, heat a larger area faster than a standard radiant stove. The distance to combustible materials is lower than a standard radiant stove, and they are therefore more suited to timber framed buildings and open plan areas.

Combustion air is controlled by adjusting the single cool touch lever which directs combustion air and allows for more complete combustion.

Churchill models are design with an external air connection allowing combustion air to come from outside and not from the room.

Features

- Curved door
- Cast iron grates
- Air cooled handle
- Closed combustion
- Single air control
- Convection Stove

Dimensions

H x W x D

- 606 x 575 x 380 convection
- 606 x 588 x 420 convection
- 660 x 595 x 460 convection
- 660 x 800 x 480 convection

kW Output

wood coal

- 4.5kW 4.2kW
- 6.0kW 6.0kW
- 8.0kW 8.0kW
- 10 kW 10 kW

Efficiency

wood coal

- 79.9% 80.0%
- 83.6% 84.8%
- 82.3% 80.8%
- 78.7% 78.3%

Class Key



Models



Churchill 4.5



Churchill 6



Churchill 8



Churchill 10





CHURCHILL LOGSTORE CONVECTION

The Churchill convection logstore is a stylish tall contemporary stove with curved door and side panels, available in outputs from 4.5kW – 10kW. This efficient stove utilises the very latest combustion technology with effective air wash and tertiary ports to aid secondary combustion.

The raised fire chamber enables easy reloading of your stove and an excellent view of the fire from your living room chair. The store area below the fire box is suitable for storing your days' fuel thus giving added convenience to the daily task of restocking wood.

The Mendip Churchill model has design at its core, the quality roller bearing ensures a smooth action to the air cooled chromium handle. The simple but sophisticated single air control system is designed to seamlessly mix primary, secondary and tertiary air to give the best possible combustion. The Churchill's' large ash pan reduces emptying intervals while the quality bespoke cast iron grate completes the robust feel of this stove.

Churchill convection models provide improved heat distribution by transferring heat to the room more effectively and efficiently than a radiant counterpart. Convection models are more suited to being placed in open plan areas as they will heat a larger area faster than a conventional stove.

Features

Curved door
Cast iron grates
Air cooled handle
Closed combustion
Single air control
Convection

Dimensions

H x W x D

800 x 575 x 380 convection
860 x 588 x 420 convection
1040 x 595 x 460 convection
1040 x 800 x 480 convection

kW Output

wood coal

4.5kW 4.2kW
6.0kW 6.0kW
8.0kW 8.0kW
10 kW 10 kW

Efficiency

wood coal

79.0% 80.0%
83.6% 84.8%
82.3% 80.8%
78.7% 78.3%

Class Key

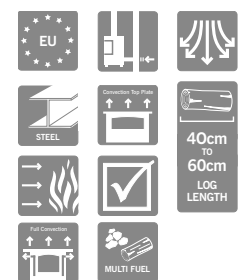

Models



Churchill 4.5kW
Convection Logstore



Churchill 6kW
Convection Logstore



Churchill 8kW
Convection Logstore



Churchill 10kW
Convection Logstore



CHURCHILL 8 DOUBLE SIDED



LOXTON / CHURCHILL DOUBLE SIDED

New to Mendip Stoves range for the winter of 2015 the Loxton and Churchill 8 double sided stove is a fantastic feature for any room. These stoves are available in our standard and logstore models, for added height, easier reloading and a useful log storage area- accessible from both sides. With both doors being able to open so reloading can occur from either side of the stove, it's ideal for an open plan room, or to heat two smaller rooms.

The Loxton comes as standard with its classic cast iron doors. Whereas the Churchill is adorned with contemporary curved doors and glass which adds to its modern aesthetic look. Both come with a cast iron grate and impressive combustion technology, as well as the single air control lever for optimal operation. All models come as standard as closed combustion capable as well as an airwash system which runs on both doors, making sure their captivating fire view can be enjoyed by everyone.

Features

Churchill
 Curved door
 Cast iron grate
 Chrome plated air cooled handle
 Closed construction
 Single air controller
 Loxton
 Cast iron door and handle

Dimensions

H x W x D

Churchill 8 DS
 660 x 510 x 650
 Loxton 8 DS
 660 x 510 x 520
 Churchill 8 DS Logstore
 965 x 510 x 650
 Loxton 8 DS Logstore
 965 x 510 x 520

kW Output

wood coal

8.0kW 8.0kW

Efficiency

wood coal

77.3% 81.8%

Class Key

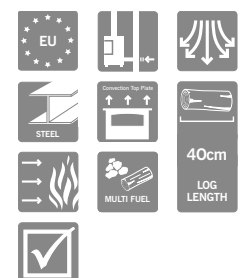

Models



Loxton 8 DS



Churchill 8 DS



Loxton 8 DS Logstore



Churchill 8 DS Logstore



LOXTON 8 DOUBLE SIDED



CHURCHILL 8 DS LOGSTORE





LOXTON 8 DOUBLE SIDED LOGSTORE





SOMERTON TALL / ACCUMULATION

The New Somerton Tall accumulation stands at an impressive 137cm tall, the 7kW stove has a central fire door with stainless steel door trims and heat storage blocks that provide a more even heat distribution while also allowing the stove to dispense heat slowly, hours after the fire has died out. This stove can give the heat you need in the evening while still keeping the room warm for breakfast the next day... It works via a Magnadense Memory system that stores heat overnight and slowly releases it into your home at the fire has gone out.

Up to eight hours of heat release in fact, while still retaining the rapid heat for which this wood burning stove is renowned. Each stove comes with 10 bricks of 6kg – 60% denser than concrete.

The space-saving cylindrical design is 81% efficient and is ideal for contemporary and classic interiors with its smooth, double location door closure and stylish steel curved handle. It also comes with a logstore at the base, can also be used for matches and firelighters, and is finished in a sleek Anthracite Black.

Features

Convection Stove
Multi-point door closure
Stainless steel handle
Cool handle
Cast iron grate

Dimensions

H x W x D

1370 x 520 x 430 tall

kW Output

wood coal

7.0kW -

Efficiency

wood coal

81.4% -

Class Key

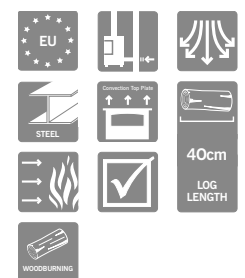

Models



Somerton II Tall



Heat Storage Blocks



SOMERTON II COMPACT



SOMERTON II PEDESTAL







SOMERTON II

Somerton II is an elegant cylindrical convection wood stove. The smooth fitted rounded door has a multi-point locking system with a single form stainless steel curved handle. The Somerton II range features the precise new universal air controller with its simple single point lever which also gives a closed combustion capability.

All models have a bespoke cast iron grate and large ash pan to give extended emptying times and have three independent air supplies ensuring more complete combustion in the firebox resulting in a cleaner burn.

The range comprises of: the Somerton II, Somerton II compact, Somerton II pedestal.

Features

Convection Stove
Multi-point door closure
Stainless steel handle
Cool handle
Cast iron grate

Dimensions

H x W x D

1100 x 520 x 430 standard
921 x 520 x 430 compact
1294 x 520 x 430 pedestal

kW Output

wood coal

7.0kW -
7.0kW -
7.0kW -

Efficiency

wood coal

81.4% -
81.4% -
81.4% -

Class Key

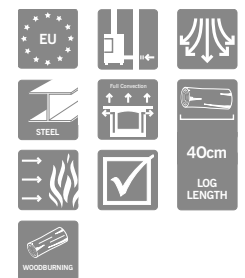

Models



Somerton II Compact



Somerton II Standard



Somerton II Pedestal



SOMERTON II SIDE GLASS





SOMERTON II SIDE GLASS

The thoughtfully designed Somerton II side glass stove has a host of visual features that enhance your enjoyment of burning wood. The tall, rounded airwashed glass and large full length polished side glass panels enable you to enjoy the flames from a wider angle. The quality finish of this anthracite painted stove is completed with stainless steel polished log door trim, and an elegantly formed one-piece stainless steel handle.

The Somerton II has design and quality at its core. The air control lever and door operation handle have been designed to be cool to touch when in use. Somerton stoves feature the innovative universal air control system, which, with movement of a single lever allows control of all three air supplies into the modern insulated combustion chamber. Internally, the chamber has bespoke cast iron grates and a large ash pan which allow for extended emptying intervals.

Features

Convection stove
Full glass side panels
Multi-point door closure
Stainless single formed handle
Cool touch handle
Cast iron grate

Dimensions

H x W x D

1100 x 495 x 460

kW Output

wood coal

7.0kW -

Efficiency

wood coal

75.3% -

Class Key

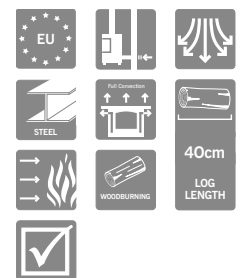

Models



Right View



Somerton II



Left view



LOXTON 10 INSET





LOXTON 10 INSET

The imposing Loxton 10 wood burning inset stove has an outstanding fire view with a large heat output, a chance to enjoy the warmth of a wood stove built in to a wall thus saving valuable floor space. The tough fully welded steel body construction is complimented with a cast iron door, internal grates and handle. The atmosphere created by this efficient well dimensioned inset stove gives a spectacular centrepiece to your home.

The modern combustion chamber gives efficient heat, tertiary air aiding the post combustion of the flue gases to maintain the clean burn of the stove. The Loxton 10 inset is fitted with warm air ducts allowing some of the heat produced to warm other parts of your home via hot air channelling. Loxton 10 Inset comes as standard with direct air supply and a flush fitting 4 sided frame making it ideal for any home.

Features

Steel construction
Cast iron door
Convactor box
4 sided frame
Cast iron handle
Large glass area
Closed combustion
Hot air ducting

Dimensions

H x W x D

Stove
640 x 730 x 410
(680)

Frame
680 x 770 x 4

kW Output

wood coal

10kW 10kW

Efficiency

wood coal

78.7% 78.3%

Class Key

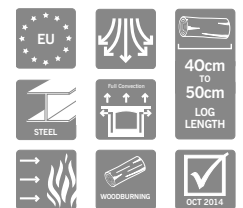

Models



Loxton 10 Inset

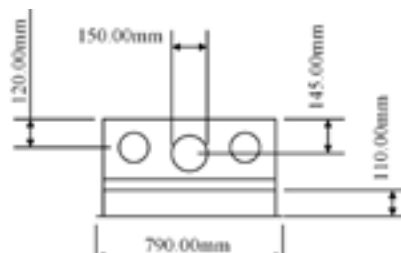

Loxton 10 Inset: Top

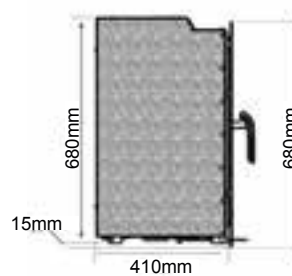

Loxton 10 Inset: Side

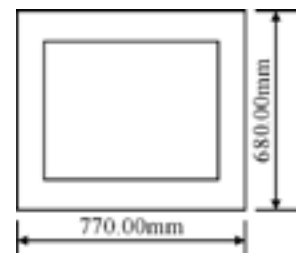

Loxton 10 Inset: Front





BURCOTT

The Burcott is an efficient multi-fuel inset stove designed to fit into a standard fireback. This stove can replace your inefficient open fire with an efficient clean and modern looking stove with the minimum of installation disruption. The Burcott has a

convection chamber around the stove providing a constant flow of hot air into your room. Convection stoves warm areas quicker than radiant models and offer a more efficient way to distribute the stoves' heat.

Features

- Burcott
- Convector box
- Cast iron door
- Milled stainless steel handle

Dimensions

H x W x D

Burcott
600 x 477 x 75

kW Output

wood coal

4.0kW 4.0kW

Efficiency

wood coal

80% 75%

Class Key



Models



Burcott

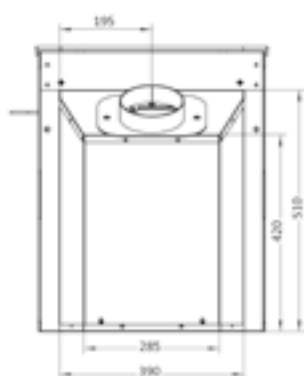





CHRISTON 400

The Christon 400 is a compact inset stove, the smallest in Christon range, it has been especially designed to fit in a standard British fireplace with the fireback removed. This compact stove well thought though and is not small on features, it has high efficiency chamber and external air capability which make it perfect for both new build and refurbishment applications.

To finish the look the Christon 400 is available with either a 4 sided or 3 sided frame to suit the installation. Installation can be achieved with the minimum of disruption to your home.

The Christon has a cast iron riddling grate system, stainless steel milled handle and stainless control handles to complete the modern look.

Features

Quality steel construction
 Large glass area
 Convector box
 3 or 4 sided frames
 Fit fireplace
 22" (560mm) h x
 16" (405mm) w

Dimensions

	H x W
Front	626 x 482
4-sided	590 x 482
3-sided	590 x 482
Box	H x W x D 554 x 392 x 345

kW Output

wood coal

4.3kW 3.7kW

Efficiency

wood coal

80% 76.2%

Class Key

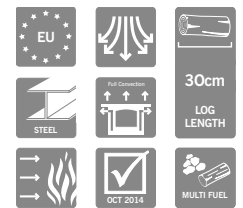

Models

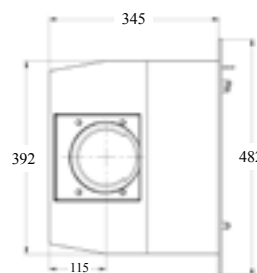
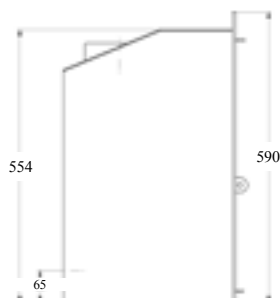

Christon 400





CHRISTON INSET 550

Inset stoves give a different vision for a wood stove, a flush built in product ideal for the more minimalist rooms. Christon wood inset fires have simple classic lines with a large window allowing the fire to show through. The well-constructed box within a box design allows good convection air flow around the firebox and into the room. The large ceramic glass window emits ample radiant heat.

The Christon inset range is manufactured in steel plate; it has a fully insulated chamber and is designed to burn wood efficiently. This stove fits comfortably in most environments providing ample heat. The clean smooth looks of the front of a Christon stove are complimented by a choice of a 3 or 4 sided frames allowing the stove to be fitted on a hearth or set higher in a flush wall application.

Features

Glass fronted door
Multi-point door locking
Closed Combustion
Singular air control
Full convector model

Dimensions

H x W x D

550 x 550 x 360

kW Output

wood coal

4.7kW -

Efficiency

wood coal

77.8% -

Class Key

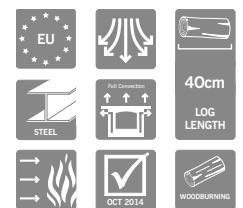

Models



Christon Inset 550

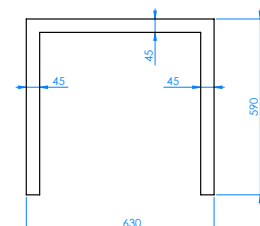
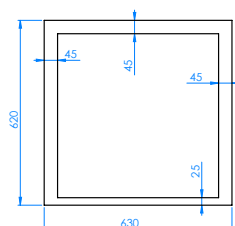





CHRISTON INSET 750

The Christon 750 offers you a panoramic sensation; the view of the fire through a wide glass is breath-taking. An inset fireplace provides a romantic, welcoming atmosphere and creates unforgettable moments for you and your family.

The large insulated chamber will accommodate a log up to 60cm long and the steel constructed box within a box design

provides good airflow around the fire box allowing convection heat to be distributed effectively to the room. If you are looking for a different vision and innovative design, this is the right choice for you. The clean smooth looks of the front of a Christon stove are complimented by the choice of a 3 or 4 sided frame which allows the stove to be fitted on a hearth or set up high in a flush wall application.

Features

Glass fronted door
Multi-point door locking
Closed Combustion
Singular air control
Full convector model

Dimensions

H x W x D

550 x 750 x 360

kW Output

wood coal

8.7kW -

Efficiency

wood coal

78.4% -

Class Key



Models

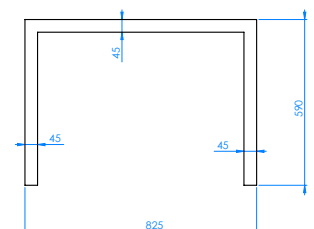
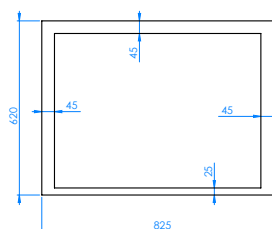

Christon Inset 750

ACCESSORIES

We have carefully chosen a range of accessories to complement our stoves. Each chosen for their practicality and good looks.



Oxmoor 1
H: 43cm



Oxmoor 2
H: 43cm



Oxmoor 3
H: 43cm



Westhay 1
H: 42cm



Westhay 2
H: 30cm



Westhay 3
H: 42cm



Lympsham
H: 77cm



Badgworth
H: 66cm



Thorney 2
H: 62cm



Dulcote
H: 51cm



Thorney 1
H: 58cm

STOVE FLOOR PLATES



Semi circle front, 12mm glass, tempered glass floor plate available in smoke glass, and clear glass.



Small Standard, 12mm glass, 20mm slate effect, tempered glass floor plate available in smoke glass, clear glass & slate effect.



Truncated, 12mm glass, 20mm, tempered glass floor plate available in smoke glass & clear glass.



Teardrop, 12mm glass, 20 slate effect, tempered glass floor plate available in smoke glass, clear glass & slate effect.

	Semi Circle	Standard Medium	Standard Large	Truncated	Teardrop	Square	Inset
	900 x 900	800 x 850	850 x 1100	930 x 1000	1000 x 1000	900 x 900	1000 x 300
Glass smoked 12mm	●	●	●	●	●	●	●
Glass Clear 12mm	●	●	●	●	●	●	●
Slate Effect 20mm	×	●	●	×	1100 x 1100 slate effect	×	×
Steel 2mm	×	×	●	×	1100 x 1100 steel	×	×

FIREPLACES

A fireplace becomes the focal point of any room, so choosing the right fireplace is essential in creating an atmosphere of warmth and style in your home.

We are passionate about our expertly crafted fireplaces and offer an quality range of traditional and contemporary fireplaces in a range of finishes.



Bradfield
Portuguese Limestone Fireplace Surround

54" Bradfield fireplace in Limestone
Vermiculite chamber
54" x 20" Filled Hearth



Regent
Marfil stone perla white surround
Pictured with black granite hearth and reeded
vermiculite chamber

54" Regent fireplace in Perla White
54" x 20" Filled Hearth



Overton
Marfil Fireplace Surround

48" Overton filled fireplace in Marfil
Black Granite filled back panel
48" x 20" Filled Hearth



Cranmore
Marfil stone perla white marble surround
Pictured with black granite hearth

54" Regent fireplace in Perla White
54" x 20" Filled Hearth

Eco Rating

Ecodesign is the European-wide programme to lower emissions. It is due to come into force in 2022. Mendip stoves have created new stoves that will meet the lower emission limits set out in the new standard now, so you can be comfortable that your new stove is one of the cleanest burning in the market today.

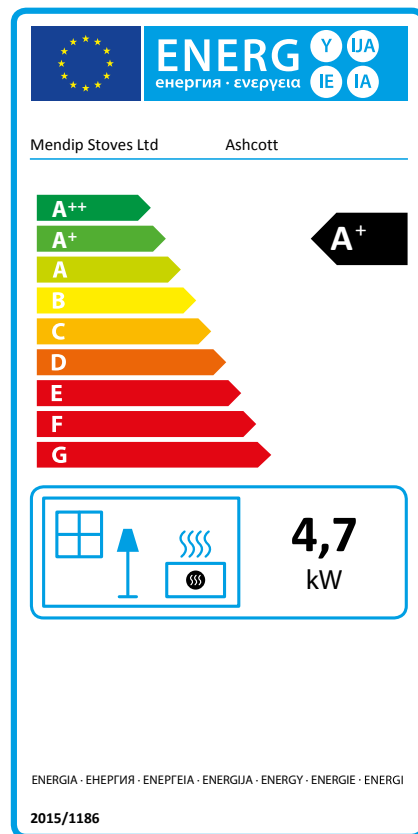

Christon 400

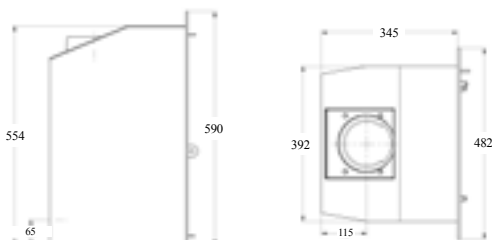

Christon 550

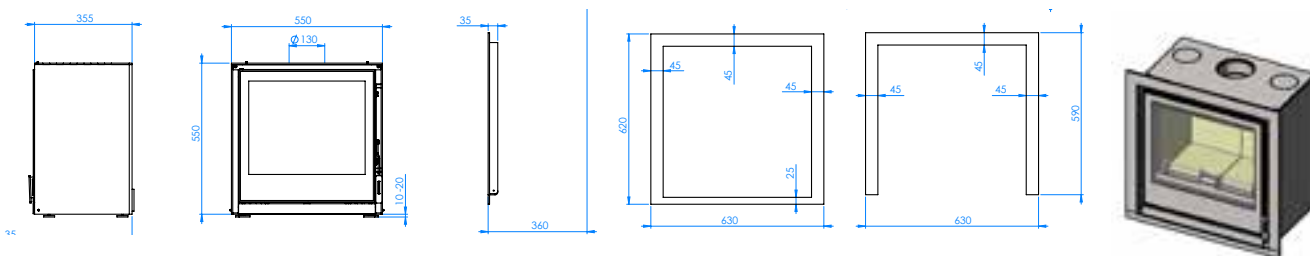

Christon 750

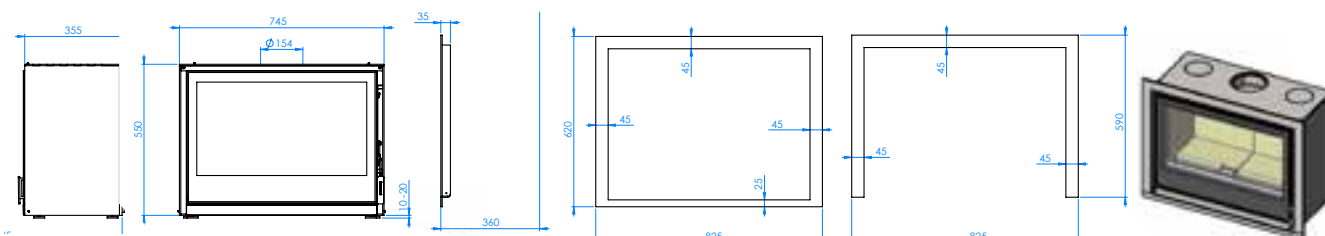

SPECIFICATIONS

Stove	Distance to combustibles (mm)	Distance from rear to centre of top outlet (mm)	Height to centre of rear outlet (mm)	Outlet diameter (mm)	Dimensions HxWxD (mm)	Weight	Output to water	Total Output Wood = w Smokeless Fuels = c	Efficiency Wood = W Smokeless Fuels = C	CO @13% O2 wood / Coal	Energy
Ashcott	Rear: 150 Sides: 400	128	455	125	575 x 424 x 370	70kg	N/A	W 4.7kW	W 80.3%	0.09	A+
The Woodland	Rear: 100 Sides: 100	130	514	125	615 x 570 x 340	110kg	N/A	W 4.5kW C 4.2kW	W 79% C 80%	0.17	A
The Woodland Logstore	Rear: 100 Sides: 100	130	674	125	775 x 570 x 340	110kg	N/A	W 4.5kW C 4.2kW	W 79% C 80%	0.17	A
Somerton STD	Rear: 200 Sides: 300	118	985	150	1100 x 520 x 430	130kg	N/A	W 7.0kW	W 81.4%	0.21	A+
Somerton Compact	Rear: 200 Sides: 300	118	778	150	921 x 520 x 430	120kg	N/A	W 7.0kW	W 81.4%	0.21	A+
Somerton Pedestal	Rear: 200 Sides: 300	118	1150	150	1294 x 520 x 430	140kg	N/A	W 7.0kW	W 81.4%	0.21	A+
Somerton Tall	Rear: 200 Sides: 300	118	985	150	1370 x 520 x 430	130kg	N/A	W 7.0kW	W 81.4%	0.21	A+
Somerton Side Glass	Rear: 100 Sides: 500	135	985	150	1100 x 495 x 460	138kg	N/A	W 7.0kW	W 75.3%	0.10	A

INSET SPECIFICATIONS

Stove	Model	Distance to Combustibles (mm)	Building in Dimensions H x W x D (mm)	Distance from rear to centre of top outlet (mm)	Outlet Diameter (mm)	Inset Box Dimensions HxWxD (mm)	Weight	Total Output	Efficiency Wood = W Smokeless Fuels = B	CO @ 13% O2 Wood / Coal	Energy
Burcott Inset stove	Convection inset	Above: 300 Sides: 75	Front: 510 x 390 x 280 Back: 420 x 285 x 280	N/A	125	600 x 477 x 355	60kg	4.4kW	W 80% C 75%	0.38W 0.36C	A+
Christon 400	Convection inset	Rear: 200 Sides: 200	560 x 400 x 350	-	125	554 x 392 x 345	75kg	4.3kW 3.7kW	W 80% C 76.2%	0.12W 0.17C	A+
Christon 550	Convection inset / Freestanding Stove	Rear: 200 Sides: 200	570 x 570 x 380	105	125	550 x 550 x 360	90kg	4.8kW	W 77.8%	0.09W	A
Christon 750	Convection inset / Freestanding Stove	Rear: 100 Sides: 100	570 x 770 x 380	105	150	550 x 750 x 360	110kg	8.7kW	W 78.4%	0.09W	A
Loxton 10 Inset	Inset frame	Rear: 100 Sides: 500	690 x 750 x 440	145	150	680 x 730 x 410 680 x 770 x 410 *Frame Dimensions	115kg	10kW	W 78.7% C 78.3%	0.20W 0.07C	A

Wood = W Smokeless Fuels = C

SPECIFICATIONS

Stove	Model	Distance to combustibles (mm)	Distance from rear to centre of top outlet (mm)	Height to centre of rear outlet (mm)	Outlet Diameter (mm)	Dimensions HxWxD (mm)	Weight	Total Output Wood = w Smokeless Fuels = c	Efficiency Wood = W Smokeless Fuels = C	CO @13% O2 wood / Coal	Energy
Loxton 3	STD	Rear: 100 Sides: 200	135	400	125	525 x 380 x 320	60kg	W&C 3.2kW	W 86% C 83%	0.25	A+
Loxton 5	STD	Rear: 100 Sides: 300	130	514	125	606 x 510 x 320	71kg	W 4.5kW C 4.2kW	W 79% C 80%	0.17	A
	5 Maxi Convector	Rear: 100 Sides: 150	130	665	125	765 x 574 x 320	82kg	W 4.5kW C 4.2kW	W 79% C 80%	0.17	
Loxton 6	STD	Rear: 100 Sides: 400	130	514	125	606 x 510 x 360	81kg	W&C 6kW	W 83.6% C 84.8%	0.16 0.13	A+
	Logstore			868		960 x 510 x 360	91kg				
Loxton 8	STD	Rear: 100 Sides: 350	140	551	150	660 x 510 x 410	91kg	W&C 8kW	W 82.3% C 80.8%	0.24 0.07	A+
	Logstore			931		1040 x 510 x 410	105kg				
Loxton 8 DS	STD	Side: 550	260	N/A	150	660 x 510 x 520	130kg	W&C 8kW	W 77.3% C 81.8%	0.28	A
	Logstore					965 x 510 x 520	140kg		W 77.3% C 81.9%		
Loxton 10	STD	Rear: 100 Sides: 500	140	551	150	660 x 710 x 410	110kg	W 10kW	W 78.7% C 78.3%	0.20 0.07	A
	Logstore			931		1040 x 710 x 410	125kg				
Churchill 5	STD	Rear: 100 Sides: 300	130	514	125	606 x 510 x 380	71kg	W 4.5kW C 4.2kW	W 79% C 80%	0.17	A
	Convection	Rear: 100 Sides: 150		715		800 x 575 x 380	87kg				
	Logstore Convection										
Churchill 6	STD	Rear: 100 Sides: 400	130	514	125	606 x 510 x 420	81kg	W&C 6kW	W 83.6% C 84.8%	0.16 0.13	A+
	STD Convection	Rear: 100 Sides: 250		768		606 x 588 x 420	88kg				
	Logstore Convection	Rear: 100 Sides: 250				860 x 588 x 420	103kg				
Churchill 8	STD	Rear: 100 Sides: 350	140	551	150	660 x 510 x 460	91kg	W&C 8kW	W 82.3% C 80.8%	0.24 0.07	A+
	Convection	Rear: 100 Sides: 200		931		660 x 595 x 460	98kg				
	Logstore Convection	Rear: 100 Sides: 200				1040 x 595 x 460	117kg				
Churchill 8 DS	STD	Sides: 550	325	N/A	150	660 x 510 x 650	130kg	W&C 8Kw	W 77.3% C 81.1%	0.28	A
	Logstore					965 x 510 x 650	145kg				
Churchill 10	STD	Rear: 100 Sides: 500	140	551	150	660 x 710 x 480	110kg	W 10kW	W 78.7% C 78.3%	0.20 0.07	A
	Convection	Rear: 100 Sides: 150		931		660 x 800 x 480	117kg				
	Logstore Convection	Rear: 100 Sides: 150				1040 x 800 x 480	122kg				



Mendip Stoves

Woodburning & Multi Fuels

Mendip Stoves Ltd
Unit H1
Mendip Industrial Estate
Mendip Road
Rooksbridge
Somerset
BS26 2UG



Tel: 01934 750 500
www.mendipstoves.co.uk
info@mendipstoves.co.uk

Mendip stoves Ltd. Have a policy of continuous improvement and reserves the right to change specification without prior notice.



Mendip Stoves are part of the Eurostove group of companies.

Issue 13.1: Nov 2017

Mendip stoves are covered by a 5 year guarantee against manufacturing defects. The guarantee covers the stove body but does not cover damage caused by faulty operation such as overheating of the stove. The guarantee does not cover damage to replaceable parts, such as glass or firebricks. For full information please consult the website.

Mendip Stoves are proud to sponsor the Woodland Trust.



The Woodland Trust, Kempton Way,
Grantham, Lincolnshire NG31 6LL
The Woodland Trust is a charity registered in England
and Wales no. 294344 and in Scotland no. SC038885.
A non-profit making company limited by guarantee.
Registered in England no. 1982873. The Woodland
Trust logo is a registered trademark.